

# SmarterGlass

state-of-the-art display solutions

## LP097QX1-SPC1

smarterglass.com  
978 997 4101  
sales@smarterglass.com



18 Henry Graf Road, Unit 1  
Newburyport, MA 01950

# SPECIFICATION FOR APPROVAL

- ( ) Preliminary Specification
- ( ) Final Specification

Title	9.7" QXGA TFT LCD
-------	-------------------

Customer	General
MODEL	

SUPPLIER	LG Display Co., Ltd.
*MODEL	LP097QX1
Suffix	SPC1

\*When you obtain standard approval, please use the above model name without suffix

APPROVED BY	SIGNATURE
/	_____
/	_____
/	_____

Please return 1 copy for your confirmation with your signature and comments.

APPROVED BY	SIGNATURE
J. K. Kim / S. Manager	_____
<b>REVIEWED BY</b>	
J. Y. Park/ Manager	_____
<b>PREPARED BY</b>	
H. S, Cha/ Engineer	_____

Product Engineering Dept.  
LG Display Co., Ltd

## Product Specification

## Contents

No	ITEM	Page
	COVER	1
	CONTENTS	2
	RECORD OF REVISIONS	3
1	GENERAL DESCRIPTION	4
2	ABSOLUTE MAXIMUM RATINGS	5
3	ELECTRICAL SPECIFICATIONS	
3-1	ELECTRICAL CHARACTREISTICS	6
3-2	INTERFACE CONNECTIONS	7
3-3	LVDS SIGNAL TIMING SPECIFICATIONS	8
3-4	SIGNAL TIMING SPECIFICATIONS	10
3-5	SIGNAL TIMING WAVEFORMS	10
3-6	COLOR INPUT DATA REFERNECE	11
3-7	POWER SEQUENCE	
4	OPTICAL SFECIFICATIONS	13
5	MECHANICAL CHARACTERISTICS	17
6	RELIABILITY	21
7	INTERNATIONAL STANDARDS	
7-1	SAFETY	22
7-2	EMC	22
8	PACKING	
8-1	DESIGNATION OF LOT MARK	23
8-2	PACKING FORM	23
9	PRECAUTIONS	24
A	APPENDIX. Enhanced Extended Display Identification Data	26





Product Specification

## 2. Absolute Maximum Ratings

The following are maximum values which, if exceeded, may cause faulty operation or damage to the unit.

**Table 1. ABSOLUTE MAXIMUM RATINGS**

Parameter	Symbol	Values		Units	Notes
		Min	Max		
Power Input Voltage	VCC	-0.3	4.0	Vdc	at 25 ± 5°C
Operating Temperature	TOP	0	50	°C	1
Storage Temperature	HST	-20	60	°C	1
Operating Ambient Humidity	HOP	10	90	%RH	1
Storage Humidity	HST	10	90	%RH	1

Note : 1. Temperature and relative humidity range are shown in the figure below.  
Wet bulb temperature should be 39°C Max, and no condensation of water.

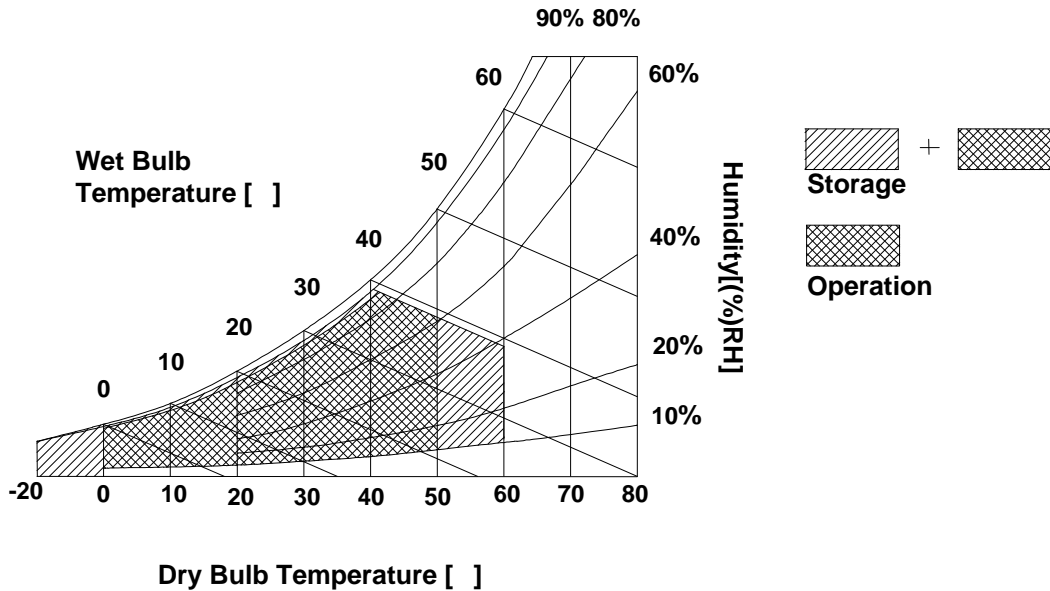

### 3. Electrical Specifications

#### 3-1. Electrical Characteristics

The LP097X02 requires two power inputs. One is employed to power the LCD electronics and to drive the TFT array and liquid crystal. The second input which powers the LED BL.

**Table 2. ELECTRICAL CHARACTERISTICS**

Parameter	Symbol	Values			Unit	Notes
		Min	Typ	Max		
MODULE :						
Power Supply Input Voltage	VCC	3.0	3.3	3.6	V <sub>DC</sub>	
Power Supply Input Current	I <sub>CC</sub> } Mosaic	-	326	375	mA	1
Power Consumption	Pc	-	1.07	1.24	Watt	1
Differential Impedance	Zm	90	100	110	Ohm	2
LED Backlight :						
(Without LED Driver)						
LED Driver input Volatge (on system)	VLED			12	V	3
Operating Current per string	I <sub>LED</sub>		18.5		mA	4
Life Time		10,000	-	-	Hrs	5

Note)

- The specified current and power consumption are under the Vcc = 3.3V , 25 , fv = 60Hz condition whereas Mosaic pattern is displayed and fv is the frame frequency.

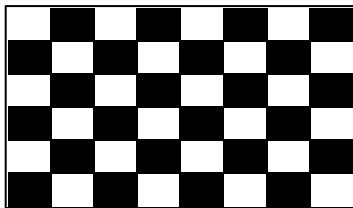

- This impedance value is needed to proper display and measured form LVDS Tx to the mating connector.
- LED input voltage must be input below than 12V to operate normally for LED Driver.**
- The typical operating current is for the typical surface luminance (L<sub>WH</sub>) in optical characteristics.
- The LED power consumption shown above does not include power of external LED driver circuit for typical current condition.
- The life time is determined as the time at which brightness of lamp is 50% compare to that of initial value at the typical lamp current.

Product Specification

3-2. Interface Connections

Table 3. MODULE CONNECTOR PIN CONFIGURATION (CN1)

Pin	Symbol	Description	Pin	Symbol	Description
1	GND	Ground	31	LED Cathode 5B	LED Cathode (Negative)
2	HPD	Hot Plug detect	32	LED Cathode 4B	LED Cathode (Negative)
3	GND	Ground	33	LED Cathode 3B	LED Cathode (Negative)
4	Vin	VCC 3.3V(typ.)	34	LED Cathode 2B	LED Cathode (Negative)
5	Vin	VCC 3.3V(typ.)	35	LED Cathode 1B	LED Cathode (Negative)
6	Vin	VCC 3.3V(typ.)	36	GND	Ground
7	Vin	VCC 3.3V(typ.)	37	LED Cathode 6A	LED Cathode (Negative)
8	GND	Ground	38	LED Cathode 5A	LED Cathode (Negative)
9	AUX_P	True Signal Auxiliary Ch.	39	LED Cathode 4A	LED Cathode (Negative)
10	AUX_N	Complement Signal Auxiliary Ch.	40	LED Cathode 3A	LED Cathode (Negative)
11	GND	Ground	41	LED Cathode 2A	LED Cathode (Negative)
12	LANE0_N	Complement Signal Link Lane 0	42	LED Cathode 1A	LED Cathode (Negative)
13	NC		43	GND	Ground
14	LANE0_P	True Signal Link Lane 0	44	NC	
15	GND	Ground	45	LED Anode 2	LED Cathode (Positive)
16	LANE1_N	Complement Signal Link Lane 1	46	LED Anode 2	LED Cathode (Positive)
17	NC		47	NC	
18	LANE1_P	True Signal Link Lane 1	48	LED Anode 1	LED Cathode (Positive)
19	GND	Ground	49	LED Anode 1	LED Cathode (Positive)
20	LANE2_N	Complement Signal Link Lane 2	50	NC	
21	NC		51	GND	Ground
22	LANE2_P	True Signal Link Lane 2			
23	GND	Ground			
24	LANE3_N	Complement Signal Link Lane 3			
25	NC				
26	LANE3_P	True Signal Link Lane 3			
27	GND	Ground			
28	GND	Ground			
29	GND	Ground			
30	LED Cathode 6B	LED Cathode (Negative)			

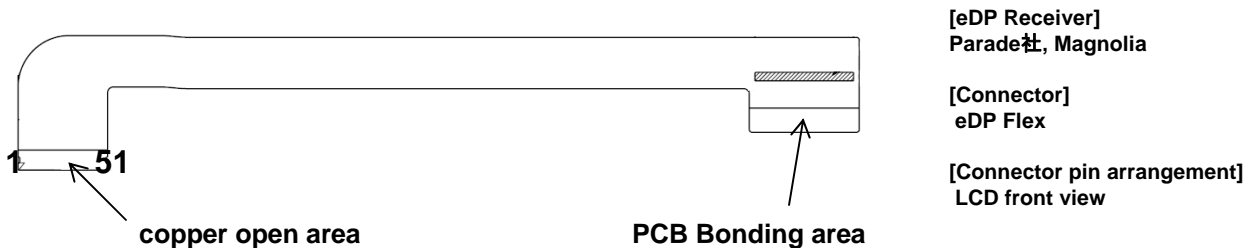



## Product Specification

### 3-3. LVDS Signal Timing Specifications

#### 3-3-1. DC Specification

The VESA Display Port related AC specification is compliant with the VESA Display Port Standard v1.1a.

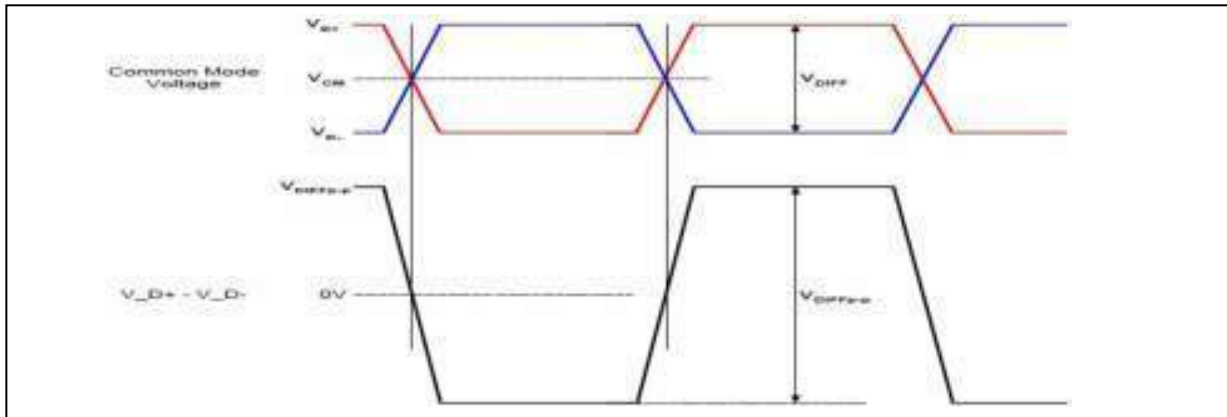

Description	Symbol	Min	Max	Unit	Notes
Differential peak-to-peak Input voltage	VDIFF p-p	120	-	mV	For high bit rate
		40	-		For reduced bit rate
Rx DC common mode voltage	VCM	0	2.0	V	-

#### 3-3-2. AC Specification

The VESA Display Port related AC specification is compliant with the VESA Display Port Standard v1.1a.

Description	Symbol	Min	Typ	Max	Unit	Notes
Unit Interval for high bit rate (2.7Gbps/lane)	UI_High_Rate	-	370	-	ps	Range is nominal $\pm 350$ ppm. DisplayPort Link Rx does not require local crystal for link clock generation
Unit Interval for high bit rate (1.62Gbps/lane)	UI_Low_Rate	-	617	-	ps	
Lane-to-Lane skew	V Rx-SKEW-INTER_PAIR	-	-	5200	ps	-
Lane intra-pair skew	V Rx-SKEW-INTRA_PAIR	-	-	100	ps	For high bit rate
		-	-	300	ps	For reduced bit rate

### 3-4. Signal Timing Specifications

This is the signal timing required at the input of the User connector. All of the interface signal timing should be satisfied with the following specifications and specifications of LVDS Tx/Rx for its proper operation.

**Table 6. TIMING TABLE**

ITEM	Symbol	Min.	Typ.	Max.	Unit	Note
DCLK	Frequency	f <sub>CLK</sub>	202	205.21	208	MHz
Hsync	Active	t <sub>WHA</sub>	2048	2048	2048	t <sub>CLK</sub>
	Period	t <sub>HP</sub>	2160	2208	2348	
	Width-Active	t <sub>WH</sub>	3	5	7	
Vsync	Active	t <sub>WVA</sub>	1536	1536	1536	t <sub>HP</sub>
	Period	t <sub>VP</sub>	1525	1549	1584	
	Width-Active	t <sub>WV</sub>	1	1	1	
Data Enable	Horizontal back porch	t <sub>HBP</sub>	3	5	7	t <sub>CLK</sub>
	Horizontal front porch	t <sub>HFP</sub>	100	150	200	
	Vertical back porch	t <sub>VBP</sub>	7	9	11	t <sub>HP</sub>
	Vertical front porch	t <sub>VFP</sub>	1	3	5	

### 3-5. Signal Timing Waveforms

Condition : VCC = 3.3V

Data Enable, Hsync, Vsync

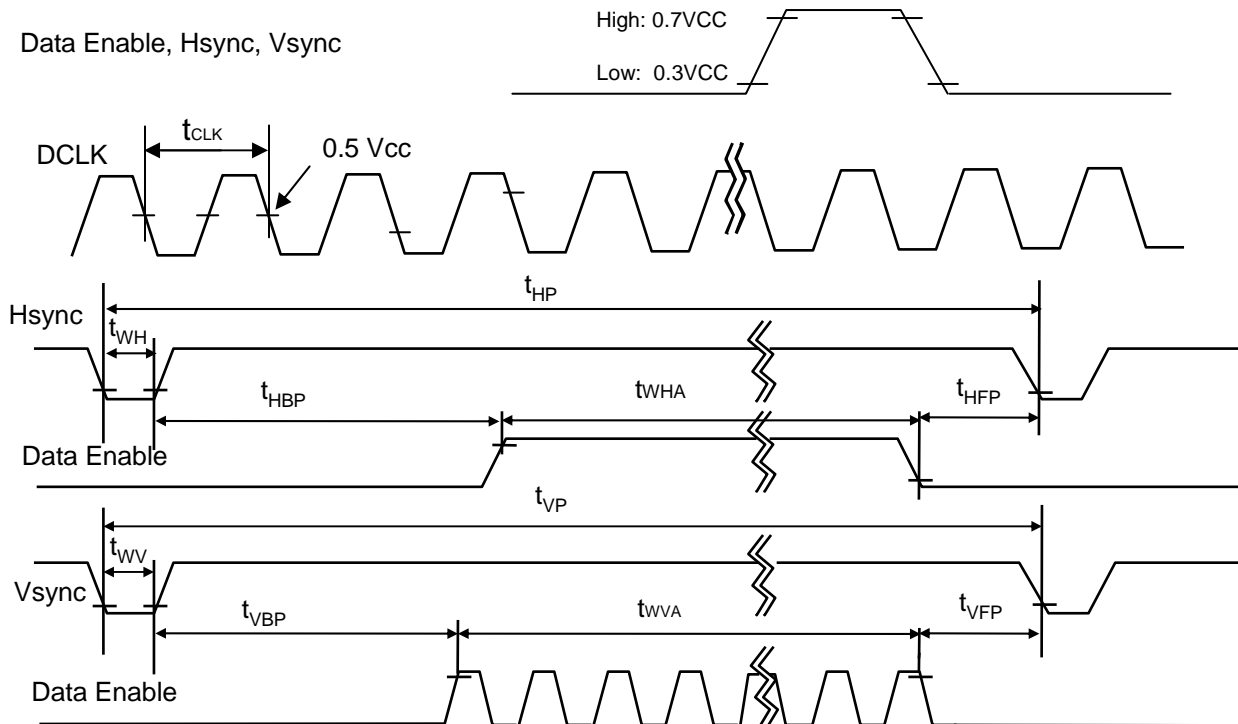

## Product Specification

### 3-6. Color Input Data Reference

The brightness of each primary color (red, green and blue) is based on the 8-bit gray scale data input for the color ; the higher the binary input, the brighter the color. The table below provides a reference for color versus data input.

**Table 7. COLOR DATA REFERENCE**

Color		Input Color Data																							
		RED								GREEN								BLUE							
		MSB				LSB				MSB				LSB				MSB				LSB			
		R7	R6	R5	R4	R3	R2	R1	R0	G7	G6	G5	G4	G3	G2	G1	G0	B7	B6	B5	B4	B3	B2	B1	B0
Basic Color	Black	0	0	0	0	0	0	0	0	0	0	0	0	0	0	0	0	0	0	0	0	0	0	0	0
	Red (255)	1	1	1	1	1	1	1	1	0	0	0	0	0	0	0	0	0	0	0	0	0	0	0	0
	Green (255)	0	0	0	0	0	0	0	0	1	1	1	1	1	1	1	1	0	0	0	0	0	0	0	0
	Blue (255)	0	0	0	0	0	0	0	0	0	0	0	0	0	0	0	0	1	1	1	1	1	1	1	1
	Cyan	0	0	0	0	0	0	0	0	1	1	1	1	1	1	1	1	1	1	1	1	1	1	1	1
	Magenta	1	1	1	1	1	1	1	1	0	0	0	0	0	0	0	0	1	1	1	1	1	1	1	1
	Yellow	1	1	1	1	1	1	1	1	1	1	1	1	1	1	1	1	0	0	0	0	0	0	0	0
	White	1	1	1	1	1	1	1	1	1	1	1	1	1	1	1	1	1	1	1	1	1	1	1	1
RED	RED (000) Dark	0	0	0	0	0	0	0	0	0	0	0	0	0	0	0	0	0	0	0	0	0	0	0	0
	RED (001)	0	0	0	0	0	0	0	1	0	0	0	0	0	0	0	0	0	0	0	0	0	0	0	0
	...																								
	RED (254)	1	1	1	1	1	1	1	0	0	0	0	0	0	0	0	0	0	0	0	0	0	0	0	0
	RED (255)	1	1	1	1	1	1	1	1	0	0	0	0	0	0	0	0	0	0	0	0	0	0	0	0
GREEN	GREEN (000) Dark	0	0	0	0	0	0	0	0	0	0	0	0	0	0	0	0	0	0	0	0	0	0	0	0
	GREEN (001)	0	0	0	0	0	0	0	0	0	0	0	0	0	0	0	1	0	0	0	0	0	0	0	0
	...																								
	GREEN (254)	0	0	0	0	0	0	0	0	1	1	1	1	1	1	1	0	0	0	0	0	0	0	0	0
	GREEN (255)	0	0	0	0	0	0	0	0	1	1	1	1	1	1	1	1	0	0	0	0	0	0	0	0
BLUE	BLUE (000) Dark	0	0	0	0	0	0	0	0	0	0	0	0	0	0	0	0	0	0	0	0	0	0	0	0
	BLUE (001)	0	0	0	0	0	0	0	0	0	0	0	0	0	0	0	0	0	0	0	0	0	0	0	1
	...																								
	BLUE (254)	0	0	0	0	0	0	0	0	0	0	0	0	0	0	0	0	1	1	1	1	1	1	1	0
	BLUE (255)	0	0	0	0	0	0	0	0	0	0	0	0	0	0	0	0	1	1	1	1	1	1	1	1

Product Specification

3-7. Power Sequence

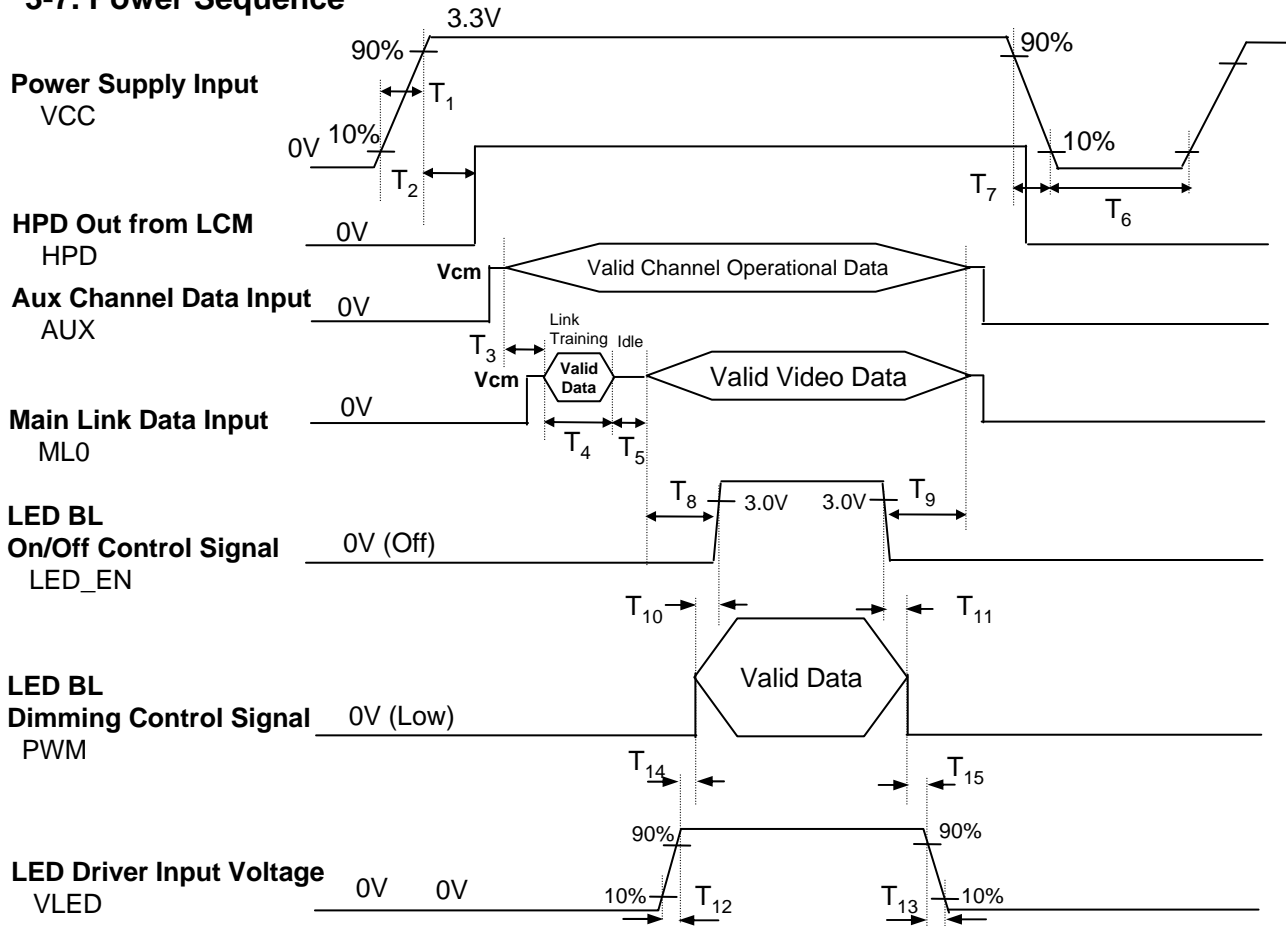

Table 6. POWER SEQUENCE TABLE

Logic Parameter	Value			Units	LED Parameter	Value			Units
	Min.	Typ.	Max.			Min.	Typ.	Max.	
$T_1$	0.5	-	10	ms	$T_9$	200	-	-	ms
$T_2$	0	-	200	ms	$T_{10}$	0	-	-	ms
$T_3$	50	75	-	ms	$T_{11}$	0	-	-	ms
$T_4$	0	-	-	ms	$T_{12}$	0.5	-	-	ms
$T_5$	0	-	-	ms	$T_{13}$	0	-	5000	ms
$T_6$	500	-	-	ms	$T_{14}$	10	-	-	ms
$T_7$	3	-	10	ms	$T_{15}$	10	-	-	ms
$T_8$	200	-	-	ms					

Note)

1. Do not insert the mating cable when system turn on.
2. Valid Data have to meet "3-3. eDP Signal Timing Specifications"
3. LVDS, LED\_EN and PWM need to be on pull-down condition on invalid status.
4. LGD recommend the rising sequence of VLED after the Vcc and valid status of LVDS turn on.

### 4. Optical Specification

Optical characteristics are determined after the unit has been 'ON' and stable for approximately 20 minutes in a dark environment at 25°C. The values specified are at an approximate distance 50cm from the LCD surface at a viewing angle of  $\phi$  and  $\theta$  equal to 0°.

FIG. 1 presents additional information concerning the measurement equipment and method.

**FIG. 1 Optical Characteristic Measurement Equipment and Method**

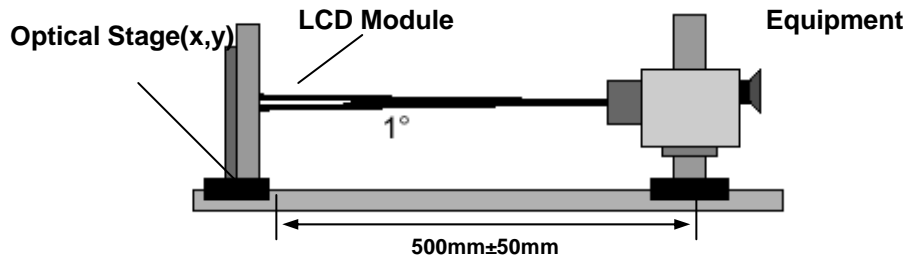

**Table 9. OPTICAL CHARACTERISTICS**  $T_a=25^\circ\text{C}$ ,  $V_{CC}=3.3\text{V}$ ,  $f_v=60\text{Hz}$ ,  $f_{CLK}=205.21\text{MHz}$ ,  $I_{LED}=18.5\text{mA}$

Parameter	Symbol	Condition	Min	Typ	Max	Units	Notes	
Average Luminance	$L_{AVE}$	5 Points ( $I_{LED}=18.5\text{mA}$ )	380	440	-	$\text{cd}/\text{m}^2$	2	
Luminance variation	$\delta_{WHITE}$	13 points	-	1.4	1.6	%	3	
C/R	-	Center 1 Point	500	600	-	-	1	
Response time		-	-	30	50	ms	4	
Viewing angle	Horizontal	$\Theta$	$\phi_x(\text{Left,Right})$	$\pm 80$	$\pm 89$	-	°	5
	Vertical	$\Theta$	$\phi_{yu}(\text{Up})$	80	89	-		
		$\Theta$	$\phi_{yd}(\text{Down})$	80	89	-		
Color Coordinates	RED	RX	0.611	0.641	0.671			
		RY	0.297	0.327	0.357			
	GREEN	GX	0.278	0.308	0.338			
		GY	0.572	0.602	0.632			
	BLUE	BX	0.120	0.150	0.180			
		BY	0.026	0.056	0.086			
WHITE	WX	0.273	0.303	0.333				
	WY	0.284	0.314	0.344				
Cross Talk	DSHA	-	-	-	4.0	%	Fig.5	
Gray Scale	-	-	Gamma 2.2				6	

## Product Specification

Note)

1. Contrast Ratio(CR) is defined mathematically as  

$$\text{Contrast Ratio} = \frac{\text{Surface Luminance with all white pixels}}{\text{Surface Luminance with all black pixels}}$$

2. Surface luminance is the average of 5 point across the LCD surface 50cm from the surface with all pixels displaying white. For more information see FIG 1.

$$L_{WH} = \text{Average}(L_1, L_2, \dots L_5)$$

3. The variation in surface luminance , The panel total variation ( $\delta_{WHITE}$ ) is determined by measuring  $L_N$  at each test position 1 through 13 and then defined as followed numerical formula.  
 For more information see FIG 2.

$$\delta_{WHITE} = \frac{\text{Maximum}(L_1, L_2, \dots L_{13})}{\text{Minimum}(L_1, L_2, \dots L_{13})}$$

4. Response time is the time required for the display to transition from white to black (rise time,  $Tr_R$ ) and from black to white(Decay Time,  $Tr_D$ ). For additional information see FIG 3.
5. Viewing angle is the angle at which the contrast ratio is greater than 10. The angles are determined for the horizontal or x axis and the vertical or y axis with respect to the z axis which is normal to the LCD surface. For more information see FIG 4.

6. Gray scale specification

 \*  $f_V = 60\text{Hz}$ 

Gray Level	Luminance [%] (Typ)
L0	0.12
L7	1.00
L15	4.30
L23	9.80
L31	19.2
L39	34.2
L47	53.5
L55	74.5
L63	100









Product Specification

<REAR VIEW>

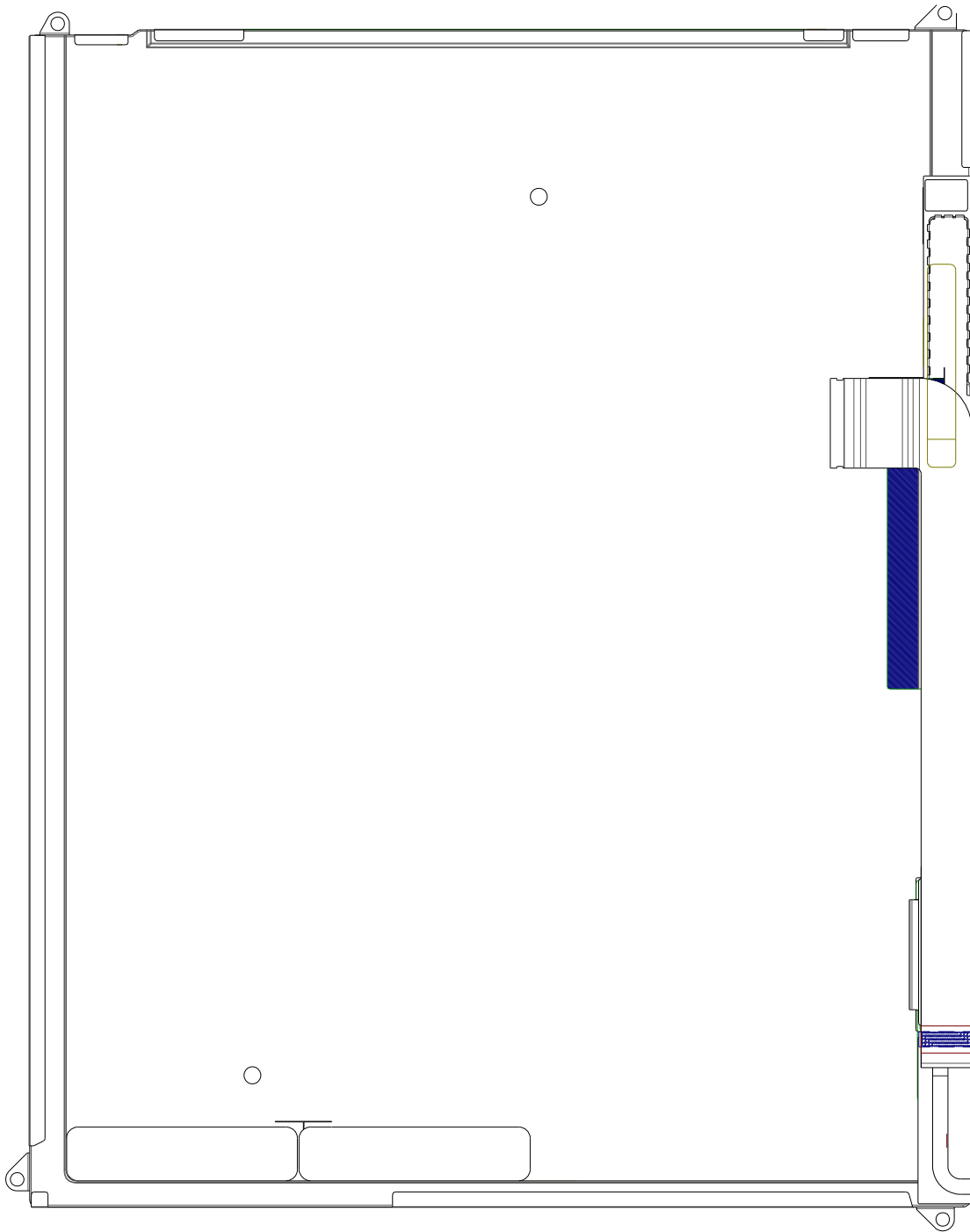

## Product Specification

## 6. Reliability

Environment test condition

No.	Test Item	Conditions
1	High temperature storage test	Ta= 60°C, 240h
2	Low temperature storage test	Ta= -20°C, 240h
3	High temperature operation test	Ta= 50°C, 50%RH, 240h
4	Low temperature operation test	Ta= 0°C, 240h
5	Vibration test (non-operating)	Sine wave, 10 ~ 500 ~ 10Hz, 1.5G, 0.37oct/min 3 axis, 1hour/axis
6	Shock test (non-operating)	Half sine wave, 180G, 2ms one shock of each six faces(i.e. run 180G 6ms for all six faces)
7	Altitude operating storage / shipment	0 ~ 10,000 feet (3,048m) 24Hr 0 ~ 40,000 feet (12,192m) 24Hr

{ Result Evaluation Criteria }

There should be no change which might affect the practical display function when the display quality test is conducted under normal operating condition.

## 7. International Standards

### 7-1. Safety

- a) UL 60950-1:2003, First Edition, Underwriters Laboratories, Inc., Standard for Safety of Information Technology Equipment.
- b) CAN/CSA C22.2, No. 60950-1-03 1<sup>st</sup> Ed. April 1, 2003, Canadian Standards Association, Standard for Safety of Information Technology Equipment.
- c) EN 60950-1:2001, First Edition, European Committee for Electrotechnical Standardization(CENELEC) European Standard for Safety of Information Technology Equipment.

### 7-2. EMC

- a) ANSI C63.4 "Methods of Measurement of Radio-Noise Emissions from Low-Voltage Electrical and Electrical Equipment in the Range of 9kHz to 40GHz. "American National Standards Institute(ANSI), 1992
- b) C.I.S.P.R "Limits and Methods of Measurement of Radio Interface Characteristics of Information Technology Equipment." International Special Committee on Radio Interference.
- c) EN 55022 "Limits and Methods of Measurement of Radio Interface Characteristics of Information Technology Equipment." European Committee for Electrotechnical Standardization.(CENELEC), 1998 ( Including A1: 2000 )

Product Specification

## 8. Packing

### 8-1. Designation of Lot Mark

a) Lot Mark

A	B	C	D	E	F	G	H	I	J	K	L	M
---	---	---	---	---	---	---	---	---	---	---	---	---

A,B,C : SIZE(INCH)  
E : MONTH

D : YEAR  
F ~ M : SERIAL NO.

Note

1. YEAR

Year	2001	2002	2003	2004	2005	2006	2007	2008	2009	2010
Mark	1	2	3	4	5	6	7	8	9	0

2. MONTH

Month	Jan	Feb	Mar	Apr	May	Jun	Jul	Aug	Sep	Oct	Nov	Dec
Mark	1	2	3	4	5	6	7	8	9	A	B	C

b) Location of Lot Mark

Serial No. is printed on the label. The label is attached to the backside of the LCD module.  
This is subject to change without prior notice.

### 8-2. Packing Form

a) Package quantity in one box : 30 pcs

b) Box Size : 478mm × 365mm × 288mm

## 9. PRECAUTIONS

Please pay attention to the followings when you use this TFT LCD module.

### 9-1. MOUNTING PRECAUTIONS

- (1) You must mount a module using holes arranged in four corners or four sides.
- (2) You should consider the mounting structure so that uneven force (ex. Twisted stress) is not applied to the module. And the case on which a module is mounted should have sufficient strength so that external force is not transmitted directly to the module.
- (3) Please attach the surface transparent protective plate to the surface in order to protect the polarizer. Transparent protective plate should have sufficient strength in order to resist external force.
- (4) You should adopt radiation structure to satisfy the temperature specification.
- (5) Acetic acid type and chlorine type materials for the cover case are not desirable because the former generates corrosive gas of attacking the polarizer at high temperature and the latter causes circuit break by electro-chemical reaction.
- (6) Do not touch, push or rub the exposed polarizers with glass, tweezers or anything harder than HB pencil lead. And please do not rub with dust clothes with chemical treatment. Do not touch the surface of polarizer for bare hand or greasy cloth. (Some cosmetics are detrimental to the polarizer.)
- (7) When the surface becomes dusty, please wipe gently with absorbent cotton or other soft materials like chamois soaks with petroleum benzene. Normal-hexane is recommended for cleaning the adhesives used to attach front / rear polarizers. Do not use acetone, toluene and alcohol because they cause chemical damage to the polarizer.
- (8) Wipe off saliva or water drops as soon as possible. Their long time contact with polarizer causes deformations and color fading.
- (9) Do not open the case because inside circuits do not have sufficient strength.

### 9-2. OPERATING PRECAUTIONS

- (1) The spike noise causes the mis-operation of circuits. It should be lower than following voltage :  
 $V = \pm 200\text{mV}$  (Over and under shoot voltage)
- (2) Response time depends on the temperature. (In lower temperature, it becomes longer.)
- (3) Brightness depends on the temperature. (In lower temperature, it becomes lower.)  
And in lower temperature, response time (required time that brightness is stable after turned on) becomes longer.
- (4) Be careful for condensation at sudden temperature change. Condensation makes damage to polarizer or electrical contacted parts. And after fading condensation, smear or spot will occur.
- (5) When fixed patterns are displayed for a long time, remnant image is likely to occur.
- (6) Module has high frequency circuits. Sufficient suppression to the electromagnetic interference shall be done by system manufacturers. Grounding and shielding methods may be important to minimize the interference.

### 9-3. ELECTROSTATIC DISCHARGE CONTROL

Since a module is composed of electronic circuits, it is not strong to electrostatic discharge. Make certain that treatment persons are connected to ground through wrist band etc. And don't touch interface pin directly.

### 9-4. PRECAUTIONS FOR STRONG LIGHT EXPOSURE

Strong light exposure causes degradation of polarizer and color filter.

### 9-5. STORAGE

When storing modules as spares for a long time, the following precautions are necessary.

- (1) Store them in a dark place. Do not expose the module to sunlight or fluorescent light. Keep the temperature between 5°C and 35°C at normal humidity.
- (2) The polarizer surface should not come in contact with any other object.  
It is recommended that they be stored in the container in which they were shipped.

### 9-6. HANDLING PRECAUTIONS FOR PROTECTION FILM

- (1) When the protection film is peeled off, static electricity is generated between the film and polarizer.  
This should be peeled off slowly and carefully by people who are electrically grounded and with well ion-blown equipment or in such a condition, etc.
- (2) The protection film is attached to the polarizer with a small amount of glue. If some stress is applied to rub the protection film against the polarizer during the time you peel off the film, the glue is apt to remain on the polarizer.  
Please carefully peel off the protection film without rubbing it against the polarizer.
- (3) When the module with protection film attached is stored for a long time, sometimes there remains a very small amount of glue still on the polarizer after the protection film is peeled off.
- (4) You can remove the glue easily. When the glue remains on the polarizer surface or its vestige is recognized, please wipe them off with absorbent cotton waste or other soft material like chamois soaked with normal-hexane.

**APPENDIX A. Enhanced Extended Display Identification Data (EEDID™) 1/3**

**TBD**



**APPENDIX A. Enhanced Extended Display Identification Data (EEDID™) 2/3**

**TBD**

**APPENDIX A. Enhanced Extended Display Identification Data (EEDID™) 3/3**

**TBD**